

IMPORTANT SAFETY INSTRUCTIONS

WARNING – When using electric appliances, basic precautions should always be followed, including the following:

- Read all instruction before using the appliance.
- To reduce risk of injury, close supervision is necessary when an appliance is used near children.
- Do not contact moving parts.
- Only use attachments and accessories recommended or sold by manufacturer.
- Do not use outdoors.
- Turn the power switch to the off position when the appliance is not in use and before servicing or cleaning.

SAVE THESE INSTRUCTIONS

INSTALLATION INSTRUCTIONS

PLEASE READ THESE INSTRUCTIONS CAREFULLY.

In the event you have any questions concerning use or care of this product, please contact the sales department at Technology Research, LLC.

50A RV POWER CORD REEL

Tools Required: Drill, Wire Stripers, 5/16 Wrench, Tape Measure, Phillips Screwdriver

Parts Included: 1 Cord Reel

Additional Parts: (Available from TRC) Switch assembly MH2021, Floor Hatch, Under coach roller guide

Installation Procedure

1. Identify compartment where the cord reel will be installed. To simplify the installation it is strongly recommended that the cord reel be installed in the compartment that stores the existing power cord.
2. Measure the compartment to insure there is enough space for the reel. Dimensional drawings are available at <http://www.shorelinereels.com>. Do not forget to leave room for the power cord to exit through the floor or wall directly in front of or below the cord reel.
3. For proper operation the cord exit must be centered with the center of the spool. The distance away from the spool is not important, only that it is centered. If the exit is not centered the cord will wrap on the side of the spool closest to the exit and could bind on the reel.
4. Place the cord reel in the compartment.
5. Mark the floor, wall or compartment where mounting bolts or screws will be located. Remove reel from compartment and drill holes for mounting bolts or screws. If reel is to be hung from the top of a compartment it must be installed into a steel frame component. Hanging reels from a wooden compartment is not recommended. If mounting on a plastic floor, a stiffening board or plate must be added.
6. Place cord reel back in compartment and install mounting screws or bolts.
7. If installing floor or wall hatch, drill or cut opening. For proper operation the cord exit must be centered with the center of the spool. Mount the floor or wall hatch.

WARNING: To Reduce the Risk of Electric Shock, disconnect the 12VDC power source prior to proceeding. This unit contains 125/250VAC. The wiring should be only done by a qualified electrician.

8. Connect the pigtail from the cord reel to the junction box or power switch where the original power cord was connected. The cord reel conductors are color coded to match the colors on the existing mains supply.

GREEN=GROUND, RED AND BLACK = HOT, WHITE=NEUTRAL

9. If using TRC switch assembly MH2021 or RV2100, mount switch housing in desired location using appropriate

Installation Procedure (cont.)

hardware. If using alternate switch not supplied by TRC, mount switch according to manufacturer's instructions. It may be necessary to mount switch after wiring to help with the routing and termination of wires. Be sure to mount and secure all wires to prevent any possible mechanical damage to outer insulation on the wires.

WARNING: To Reduce the Risk of Electric Shock, disconnect the 12VDC power source prior to proceeding.

10. Find the nearest 12 VDC power source. The power source must be from a circuit protected by a 20 Amp circuit breaker. Using power from a compartment is not recommended as these normally do not have a high enough amperage rating.
11. Route the wiring to the desired position of the switch previously located.
12. If using TRC supplied switch assembly MH2021 refer to wiring diagram (Figure A). If using part RV2100, follow instructions provided with the switchbox. If using an alternate switch not supplied by TRC, refer to wiring diagram (Figure B). Alternate switch must be a DPDT, (ON) OFF (ON) rocker type capable of handling 20 Amps VDC. All wiring regardless of switch used must be 14 AWG with all applicable terminals sized appropriately.
13. Reconnect the 12 VDC power supply.
14. Test the unit by following steps listed in **OPERATING INSTRUCTIONS**

**Figure A:
12 Volt Motor Circuit Wiring Diagram**

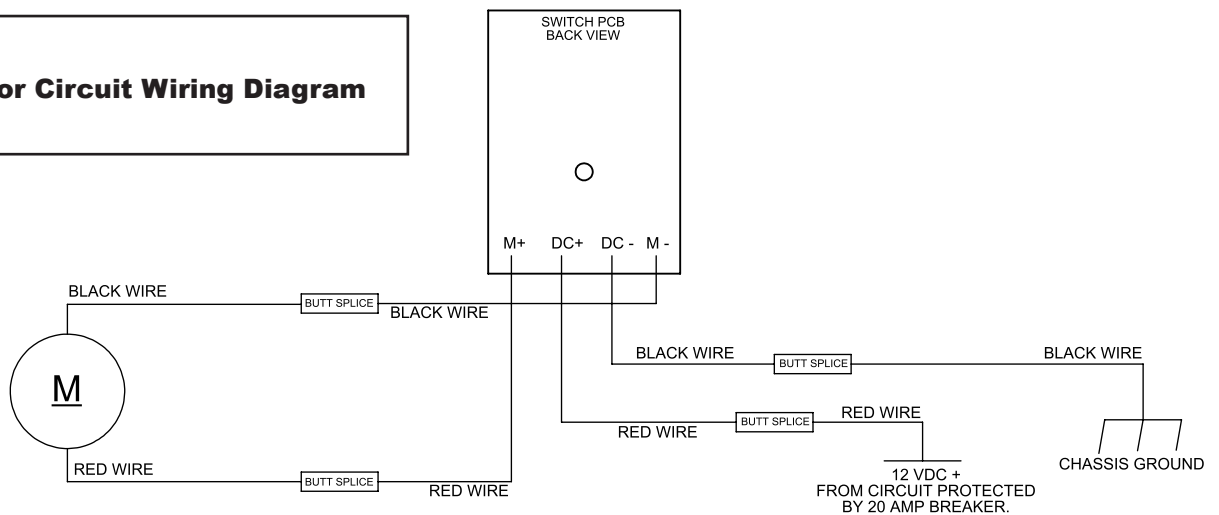

**Figure B:
12 Volt Motor Circuit Wiring Diagram**

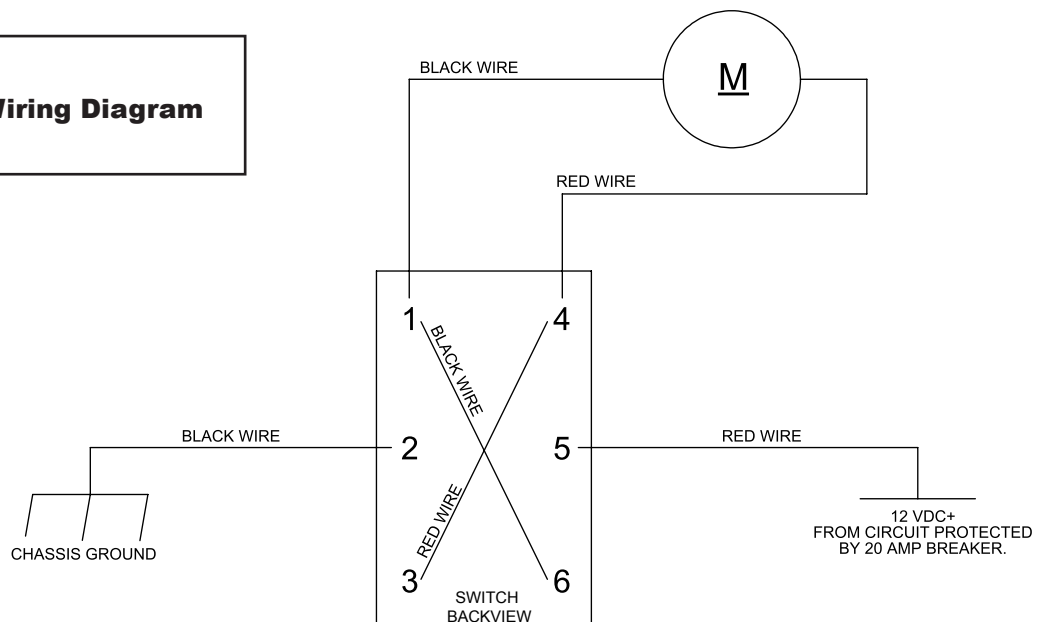

OPERATING INSTRUCTIONS

This unit is designed with a clutch type drive to allow direct engagement during retract and clutch disengagement to allow for free spooling during release. These features are controlled using the rocker switch assembly MH2021, RV2100 or equivalent previously installed. To correctly operate the unit, follow the steps listed below. If the unit does not perform according to the instructions below first recheck wiring for any issues.

MOTOR OPERATION

1. Ensure power is being supplied by the 12 VDC source.
2. Locate the switch installed. If using TRC switches, identify the label markings "RETRACT" located at the top switch position and "RELEASE" located at the bottom switch position.
3. To retract the cord back onto the reel simply press and hold the switch in the top "RETRACT" position until the desired amount of cord is returned to the reel.
4. To release the cord from the reel, press the switch **MOMENTARILY** in the bottom "RELEASE" position. This unlocks the spool and allows for the cord to be manually pulled to a desired length. **DO NOT** attempt to pull cord from the reel without first pressing the switch momentarily in the bottom "RELEASE" position. Only a **MOMENTARY** press of the switch in the "RELEASE" position will be needed. **DO NOT** attempt to continuously hold the "RELEASE" switch position, doing so will cause the cord to unravel on the spool.

CORD OPERATION

Use only approved applicable outlets. Cord connector has a built-in Easy-T-Pull handle for easy disconnect.

USER-MAINTENANCE INSTRUCTIONS

This unit does not have any user serviceable parts. The user can perform periodic inspection of the cord to insure it is still in usable condition.

DO NOT use if the cord is damaged.

Tampering with the unit in any other way not mentioned in the **USER-MAINTENANCE INSTRUCTIONS** will void the warranty.

See **WARRANTY INFORMATION**.

WARRANTY INFORMATION

TRC warrants that its devices are free from defects in materials and workmanship for a period of one year from the date of original purchase. This one year warranty is in lieu of all other warranties, obligation, or liabilities expressed or implied by the company. Any properly installed device that proves defective in normal use will be repaired or replaced at TRC's option provided the unit is returned through an authorized TRC dealer or representative or ship the unit directly to TRC following the procedure below:

1. Contact TRC Customer Support at 1-800-780-4324 to obtain a Return Materials Number.
2. Properly package returned unit.
3. Display Return Materials Number on outside of box.
4. Include Proof of Purchase, including date of purchase.
5. Supply full written description of the problem.
6. Specify your name, address, and daytime phone number.
7. Ship unit postage prepaid directly to:

Return Materials Department - Technology Research LLC
5250 140th Avenue North - Clearwater, Florida 33760

Any questions regarding this warranty, please contact TRC by phone at 1-800-780-4324 or by email at productinfo@trci.net.

Warranty is void if the device has been altered, misused and/or abused in any way. TRC cannot assume responsibility for customer alterations, acts of God, or any other factors not under the control of TRC. TRC cannot assume responsibility for damage in handling of shipment. TRC shall have no responsibility for installation of this device or for any personal injury, property damage, any incidental, contingent, or consequential damages of any kind resulting in defects or failure of the unit to function in the event of a ground fault in the circuit it is protecting. Implied warranties (if any) including but not limited to implied warranties of fitness for a particular purpose and merchantability are limited in duration to a period ending one year from the date of original customer purchase. The exclusive remedy for breach of the limited warranty contained herein is the repair or replacement of the defective product at TRC's option. In no case shall TRC's liability under any other remedy prescribed by law exceed the purchase price. Some states do not allow the exclusion or limitation of incidental or consequential damages or allow disclaimers or modifications of or limitation on how long an implied warranty lasts, so the above limitations may not apply to you. This warranty gives you specific legal rights and you may also have other rights which may vary from state to state.

